



US009614168B2

(12) **United States Patent**
Zhang et al.

(10) **Patent No.:** **US 9,614,168 B2**
(45) **Date of Patent:** **Apr. 4, 2017**

(54) **FLEXIBLE DISPLAY PANEL WITH BENT SUBSTRATE**

(71) Applicant: **Apple Inc.**, Cupertino, CA (US)

(72) Inventors: **Zhen Zhang**, San Jose, CA (US); **Yi Tao**, San Jose, CA (US); **Paul S. Drzaic**, Morgan Hill, CA (US); **Joshua G. Wurzel**, Sunnyvale, CA (US)

(73) Assignee: **Apple Inc.**, Cupertino, CA (US)

(*) Notice: Subject to any disclaimer, the term of this patent is extended or adjusted under 35 U.S.C. 154(b) by 0 days.

(21) Appl. No.: **14/987,129**

(22) Filed: **Jan. 4, 2016**

(65) **Prior Publication Data**

US 2016/0204366 A1 Jul. 14, 2016

Related U.S. Application Data

(60) Provisional application No. 62/102,284, filed on Jan. 12, 2015.

(51) **Int. Cl.**

H01L 27/32 (2006.01)
H01L 51/00 (2006.01)
H01L 23/498 (2006.01)
H01L 23/538 (2006.01)
H01L 51/52 (2006.01)

(52) **U.S. Cl.**

CPC **H01L 51/0097** (2013.01); **H01L 23/4985** (2013.01); **H01L 23/5387** (2013.01); **H01L 27/326** (2013.01); **H01L 27/3276** (2013.01); **H01L 51/004** (2013.01);

(Continued)

(58) **Field of Classification Search**

CPC H01L 27/326; H01L 23/5387; H01L 23/4985; H01L 51/0097

See application file for complete search history.

(56) **References Cited**

U.S. PATENT DOCUMENTS

4,507,170 A 3/1985 Myhre
5,694,190 A 12/1997 Matsumoto et al.
(Continued)

FOREIGN PATENT DOCUMENTS

CN 102568377 7/2012
EP 1533852 5/2005
(Continued)

OTHER PUBLICATIONS

Raff et al, U.S. Appl. No. 15/016,772, filed Feb. 5, 2016.

Primary Examiner — Phat X Cao

(74) *Attorney, Agent, or Firm* — Treyz Law Group, P.C.; G. Victor Treyz; Zachary D. Hadd

(57) **ABSTRACT**

A display may have an array of organic light-emitting diodes that form an active area on a flexible substrate. Metal traces may extend between the active area and an inactive area of the flexible substrate. Display driver circuitry such as a display driver integrated circuit may be coupled to the inactive area. The metal traces may extend across a bend region in the flexible substrate. The flexible substrate may be bent in the bend region. The flexible substrate may be made of a thin flexible material to reduce metal trace bending stress. A coating layer in the bend region may be provided with an enhanced elasticity to allow its thickness to be reduced. The flexible substrate may be bent on itself and secured within an electronic device without using a mandrel.

28 Claims, 10 Drawing Sheets

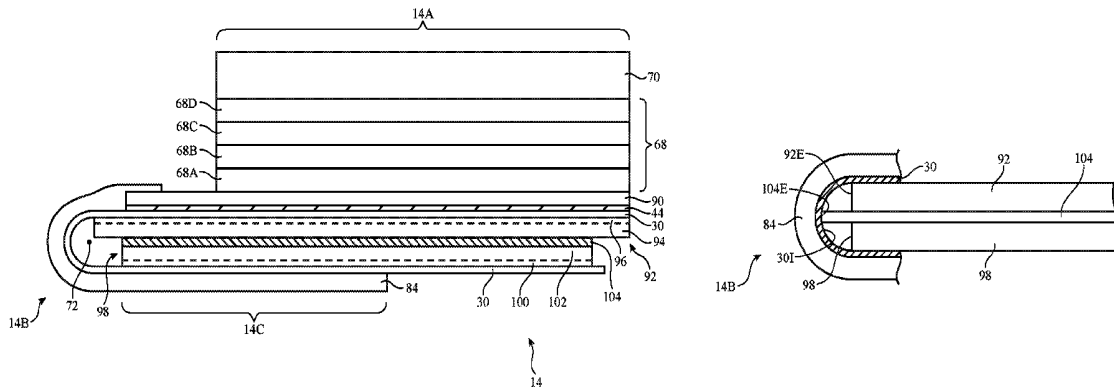

(52) U.S. Cl.
 CPC .. *H01L 51/5253* (2013.01); *H01L 2251/5338*
 (2013.01); *H01L 2251/558* (2013.01)

(56) **References Cited**

U.S. PATENT DOCUMENTS

5,717,556 A 2/1998 Yanagida
 5,777,855 A 7/1998 Yokajty
 6,104,464 A 8/2000 Adachi et al.
 6,201,346 B1 3/2001 Kusaka
 6,483,714 B1 11/2002 Kabumoto et al.
 6,498,592 B1 12/2002 Matthies
 6,633,134 B1 10/2003 Kondo
 6,717,057 B1 4/2004 Segall et al.
 7,816,856 B2 10/2010 Cok et al.
 8,106,309 B2 1/2012 Hwang
 8,319,725 B2 11/2012 Okamoto et al.
 8,434,909 B2 5/2013 Nichol et al.
 8,492,969 B2 7/2013 Lee et al.
 8,723,824 B2 5/2014 Myers et al.
 8,724,304 B2 5/2014 Raff et al.
 8,804,347 B2 8/2014 Martisaukas
 8,976,141 B2 3/2015 Myers et al.
 9,209,207 B2 12/2015 Park et al.
 9,256,250 B2 2/2016 Raff et al.
 2002/0097352 A1 7/2002 Houdeau
 2005/0078099 A1 4/2005 Amundson et al.
 2005/0212419 A1 9/2005 Vazan et al.
 2006/0231844 A1 10/2006 Carter
 2008/0024060 A1 1/2008 Jonnalagadda et al.
 2008/0241549 A1 10/2008 Seon et al.
 2008/0248191 A1 10/2008 Daniels
 2009/0021666 A1 1/2009 Chen
 2009/0148678 A1 6/2009 Hwang
 2009/0189835 A1 7/2009 Kim et al.
 2010/0148654 A1 6/2010 Yan et al.
 2010/0308335 A1 12/2010 Kim et al.
 2010/0308355 A1 12/2010 Hsieh et al.
 2011/0007042 A1 1/2011 Miyaguchi
 2011/0241563 A1 10/2011 Kim et al.
 2012/0146886 A1 6/2012 Minami et al.

2012/0208306 A1 8/2012 Haas et al.
 2012/0307423 A1 12/2012 Bohn et al.
 2013/0026505 A1 1/2013 Lee et al.
 2013/0081756 A1 4/2013 Franklin et al.
 2013/0112984 A1 5/2013 Kim et al.
 2013/0180882 A1 7/2013 Hamers et al.
 2014/0042406 A1 2/2014 Degner et al.
 2014/0092338 A1 4/2014 Miyazaki et al.
 2014/0131897 A1* 5/2014 Yu H01L 23/4985
 257/783
 2014/0184057 A1 7/2014 Kim et al.
 2014/0203703 A1 7/2014 Maatta
 2014/0217382 A1 8/2014 Kwon et al.
 2014/0239276 A1 8/2014 Lin et al.
 2014/0240985 A1 8/2014 Kim et al.
 2014/0267950 A1 9/2014 Kang et al.
 2014/0299884 A1 10/2014 Park et al.
 2014/0306941 A1 10/2014 Kim et al.
 2014/0333858 A1 11/2014 Martisaukas
 2015/0091434 A1 4/2015 Kim
 2015/0130767 A1 5/2015 Myers et al.
 2015/0227227 A1 8/2015 Myers et al.
 2015/0230331 A1 8/2015 Lee
 2015/0363030 A1 12/2015 Nam et al.

FOREIGN PATENT DOCUMENTS

JP 2008033095 2/2008
 JP 2009094099 4/2009
 JP 2012128006 7/2012
 TW 548185 8/2003
 TW 201002125 1/2010
 TW 201044899 12/2010
 TW M429927 5/2012
 TW 201229179 7/2012
 TW 201419973 5/2014
 TW 201440582 10/2014
 WO 0027172 A1 5/2000
 WO 2008001051 1/2008
 WO 2012078040 6/2012

* cited by examiner

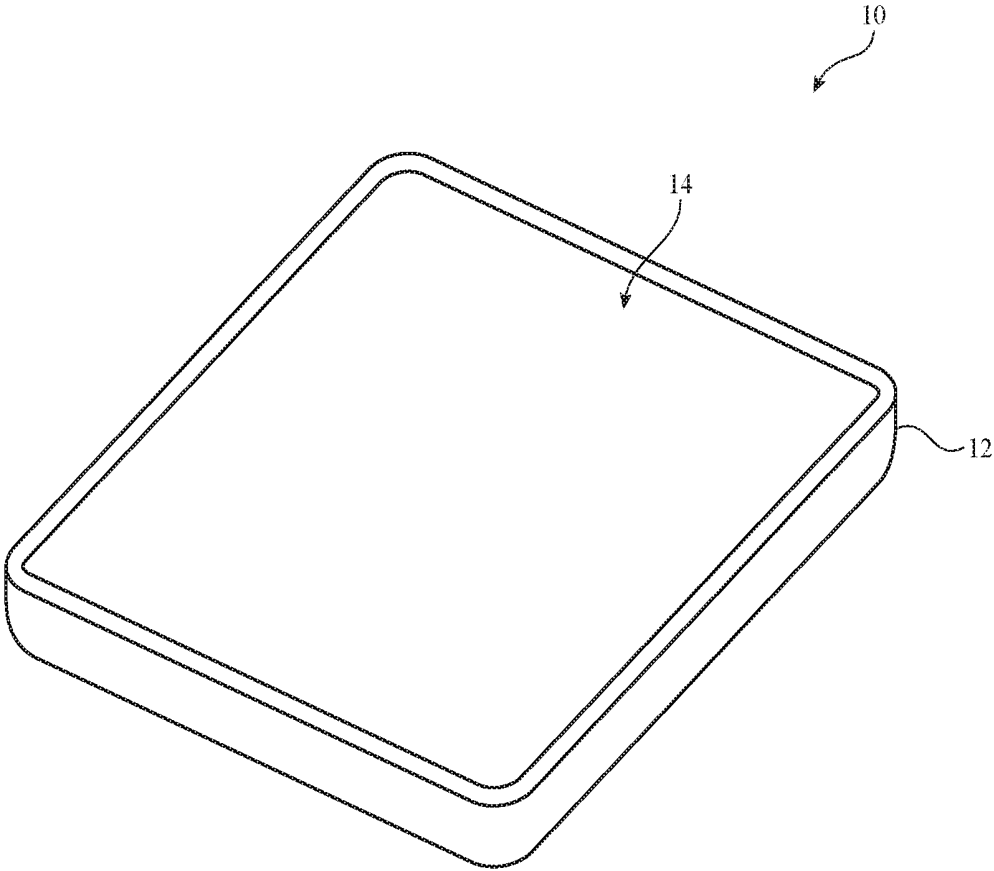

FIG. 1

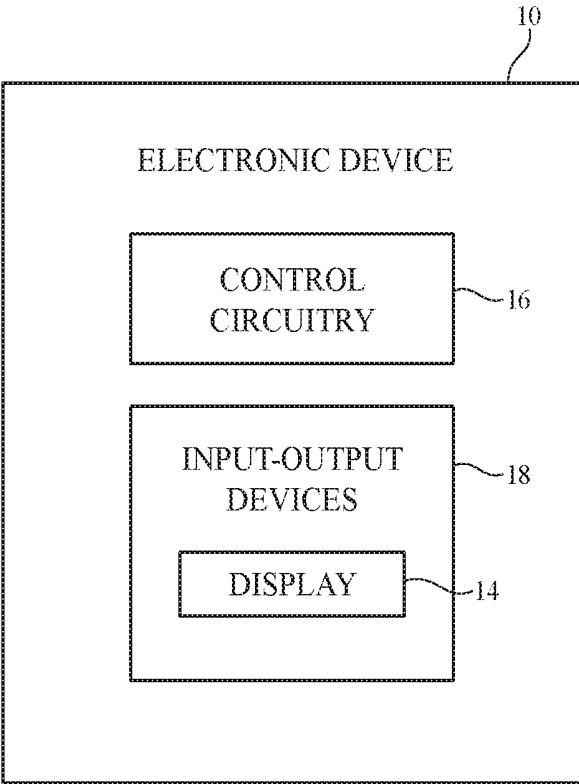

FIG. 2

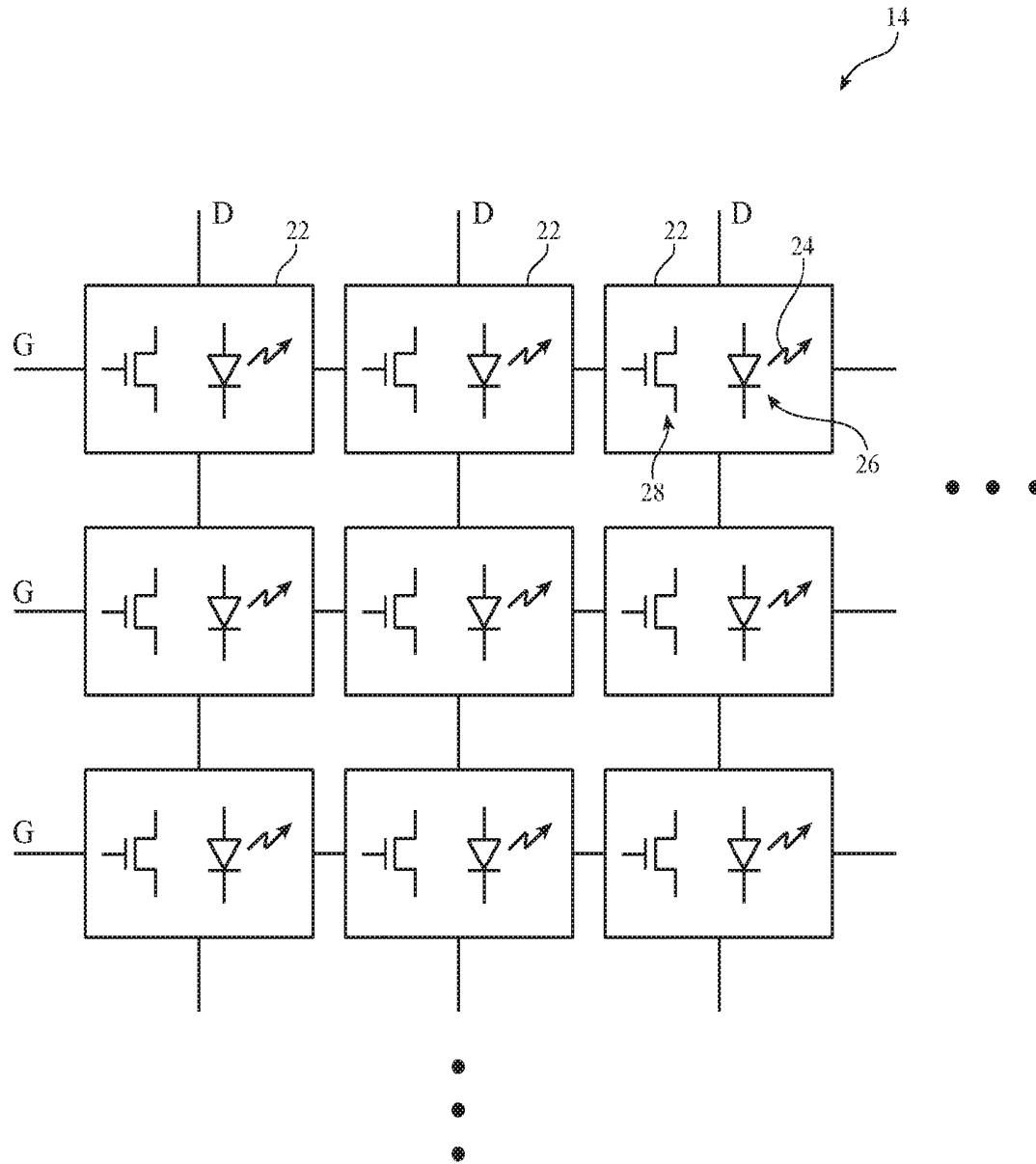

FIG. 3

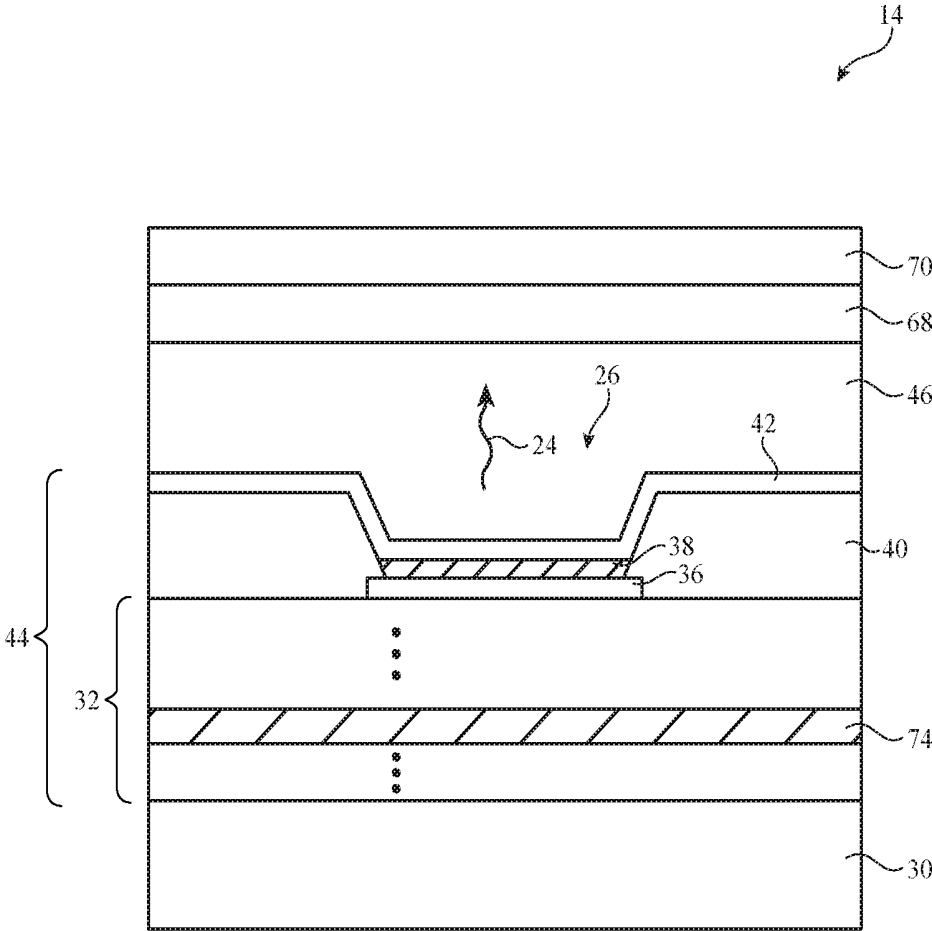

FIG. 4

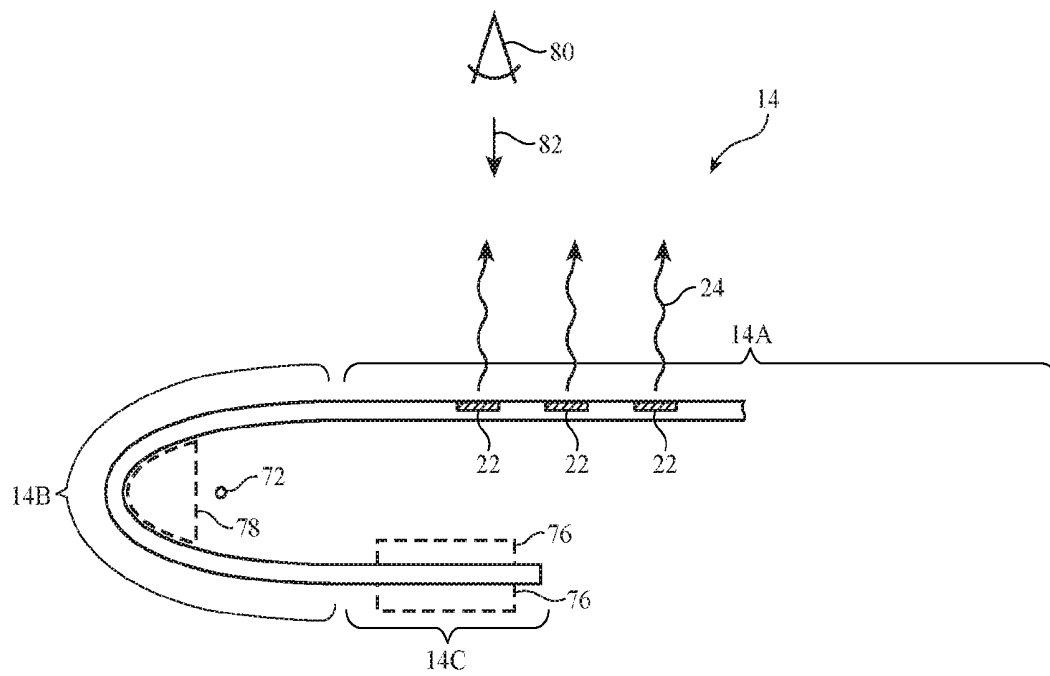

FIG. 6

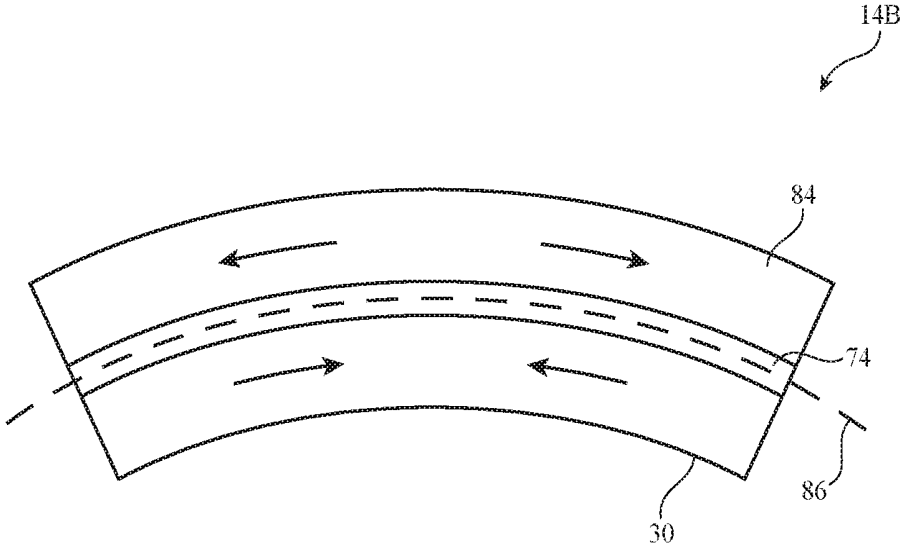

FIG. 7

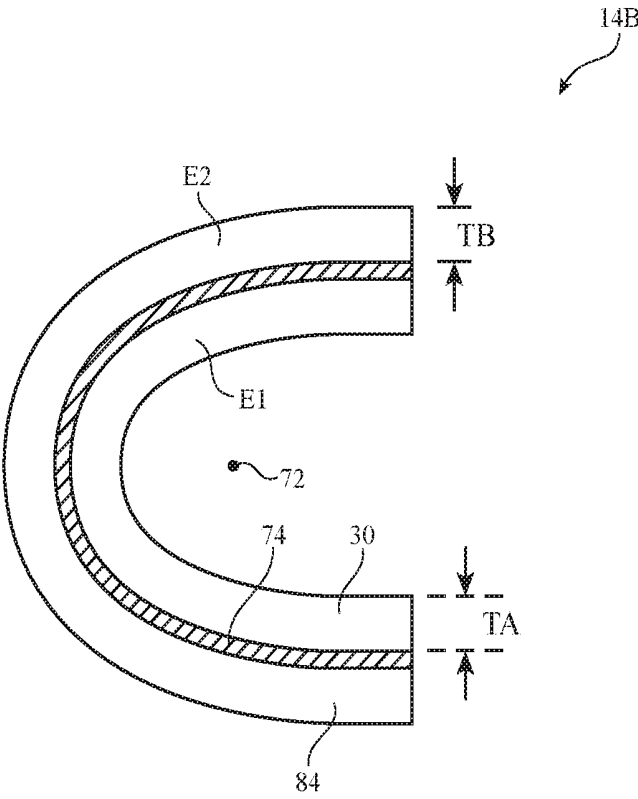

FIG. 8

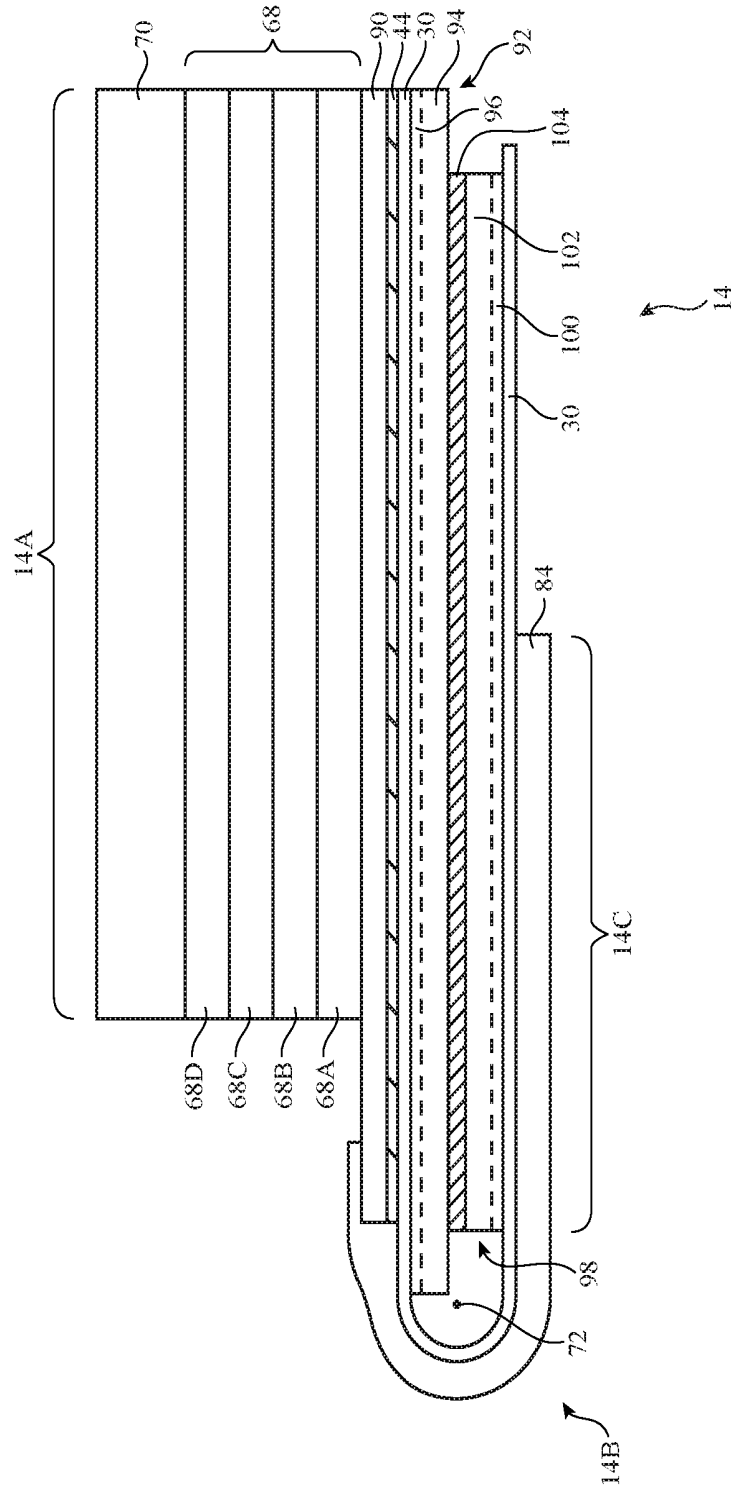

FIG. 9

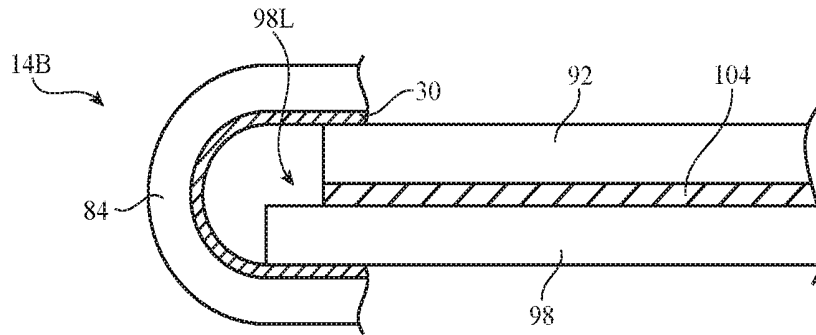

FIG. 10

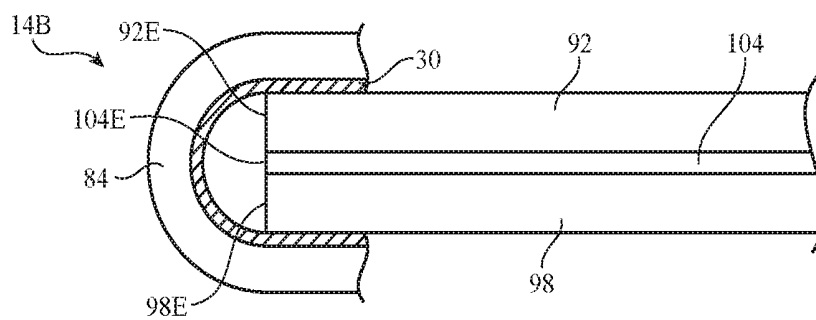

FIG. 11

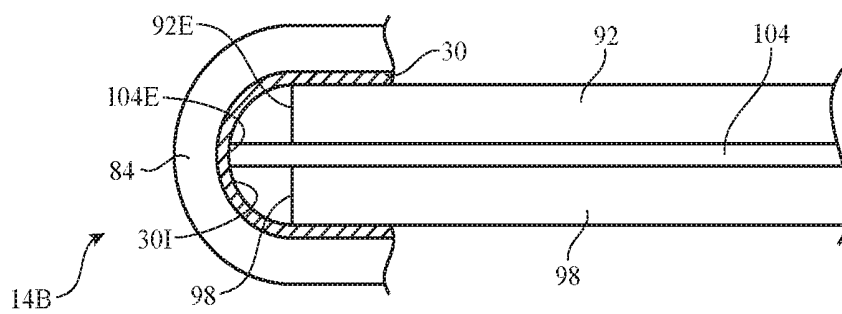

FIG. 12

FLEXIBLE DISPLAY PANEL WITH BENT SUBSTRATE

This application claims the benefit of provisional patent application No. 62/102,284, filed Jan. 12, 2015, which is hereby incorporated by reference herein in its entirety.

BACKGROUND

This relates generally to electronic devices with displays, and, more particularly, to displays with bent portions.

Electronic devices often include displays. Displays such as organic light-emitting diode displays may be formed on flexible substrates. Displays with flexible substrates may be bent. For example, it may be desirable to bend an edge of a display to hide inactive display components along the edge of the display from view.

The process of bending a display can create stresses within the structures of the display. For example, bent metal traces may become stressed. Stress-induced damage such as cracks may adversely affect display reliability.

It would therefore be desirable to be able to provide improved displays with bent portions.

SUMMARY

A display may have an array of organic light-emitting diodes that form an active area on a flexible substrate. Metal traces may extend between the active area and an inactive area of the flexible substrate. Display driver circuitry such as a display driver integrated circuit may be coupled to the inactive area. The metal traces may extend across a bend region in the flexible substrate. The flexible substrate may be bent in the bend region.

The flexible substrate may be made of a thin flexible material to reduce metal trace bending stress. A coating layer in the bend region may be provided with an enhanced elasticity to allow its thickness to be reduced. The flexible substrate may be bent on itself and secured within an electronic device without using a mandrel.

BRIEF DESCRIPTION OF THE DRAWINGS

FIG. 1 is a perspective view of an illustrative electronic device having a display in accordance with an embodiment.

FIG. 2 is a schematic diagram of an illustrative electronic device having a display in accordance with an embodiment.

FIG. 3 is a top view of an illustrative display in an electronic device in accordance with an embodiment.

FIG. 4 is a cross-sectional side view of a portion of an illustrative organic light-emitting diode display in accordance with an embodiment.

FIG. 5 is perspective view of an illustrative display with a bent portion in accordance with an embodiment.

FIG. 6 is a cross-sectional side view of an illustrative display with a bent portion in accordance with an embodiment.

FIG. 7 is a cross-sectional side view of an illustrative bent substrate showing how a neutral stress plane may be aligned with metal traces on the substrate using a coating layer in accordance with an embodiment.

FIG. 8 is a cross-sectional side view of an illustrative display having a flexible substrate with a coating layer that has been bent in accordance with an embodiment.

FIG. 9 is a cross-sectional side view of an illustrative display with a bent flexible substrate in accordance with an embodiment.

FIGS. 10, 11, and 12 are cross-sectional side views of illustrative layers in displays with bent flexible substrates in accordance with embodiments.

DETAILED DESCRIPTION

An illustrative electronic device of the type that may be provided with a display is shown in FIG. 1. Electronic device 10 may be a computing device such as a laptop computer, a computer monitor containing an embedded computer, a tablet computer, a cellular telephone, a media player, or other handheld or portable electronic device, a smaller device such as a wrist-watch device, a pendant device, a headphone or earpiece device, a device embedded in eyeglasses or other equipment worn on a user's head, or other wearable or miniature device, a television, a computer display that does not contain an embedded computer, a gaming device, a navigation device, an embedded system such as a system in which electronic equipment with a display is mounted in a kiosk or automobile, equipment that implements the functionality of two or more of these devices, or other electronic equipment. In the illustrative configuration of FIG. 1, device 10 is a portable device such as a cellular telephone, media player, tablet computer, wrist device, or other portable computing device. Other configurations may be used for device 10 if desired. The example of FIG. 1 is merely illustrative.

In the example of FIG. 1, device 10 includes a display such as display 14 mounted in housing 12. Housing 12, which may sometimes be referred to as an enclosure or case, may be formed of plastic, glass, ceramics, fiber composites, metal (e.g., stainless steel, aluminum, etc.), other suitable materials, or a combination of any two or more of these materials. Housing 12 may be formed using a unibody configuration in which some or all of housing 12 is machined or molded as a single structure or may be formed using multiple structures (e.g., an internal frame structure, one or more structures that form exterior housing surfaces, etc.).

Display 14 may be a touch screen display that incorporates a layer of conductive capacitive touch sensor electrodes or other touch sensor components (e.g., resistive touch sensor components, acoustic touch sensor components, force-based touch sensor components, light-based touch sensor components, etc.) or may be a display that is not touch-sensitive. Capacitive touch screen electrodes may be formed from an array of indium tin oxide pads or other transparent conductive structures.

Display 14 may include an array of display pixels formed from liquid crystal display (LCD) components, an array of electrophoretic display pixels, an array of plasma display pixels, microelectromechanical (MEMS) shutter pixels, electrowetting pixels, micro-light-emitting diodes (small crystalline semiconductor die), organic light-emitting diodes (e.g., a thin-film organic light-emitting diode display), quantum dot light-emitting diodes, or display pixels based on other display technologies. The array of display pixels may display images for a user in active area of display 14. The active area may be surrounded on one or more sides by inactive border regions.

Display 14 may be protected using a display cover layer such as a layer of transparent glass or clear plastic. Openings may be formed in the display cover layer. For example, an opening may be formed in the display cover layer to accommodate a button, a speaker port, or other component. Openings may be formed in housing 12 to form communi-

cations ports (e.g., an audio jack port, a digital data port, etc.), to form openings for buttons, etc.

FIG. 2 is a schematic diagram of device 10. As shown in FIG. 2, electronic device 10 may have control circuitry 16. Control circuitry 16 may include storage and processing circuitry for supporting the operation of device 10. The storage and processing circuitry may include storage such as hard disk drive storage, nonvolatile memory (e.g., flash memory or other electrically-programmable-read-only memory configured to form a solid state drive), volatile memory (e.g., static or dynamic random-access-memory), etc. Processing circuitry in control circuitry 16 may be used to control the operation of device 10. The processing circuitry may be based on one or more microprocessors, microcontrollers, digital signal processors, baseband processors, power management units, audio chips, application specific integrated circuits, etc.

Input-output circuitry in device 10 such as input-output devices 18 may be used to allow data to be supplied to device 10 and to allow data to be provided from device 10 to external devices. Input-output devices 18 may include buttons, joysticks, scrolling wheels, touch pads, key pads, keyboards, microphones, speakers, tone generators, vibrators, cameras, sensors, light-emitting diodes and other status indicators, data ports, etc. A user can control the operation of device 10 by supplying commands through input-output devices 18 and may receive status information and other output from device 10 using the output resources of input-output devices 18. Input-output devices 18 may include one or more displays such as display 14.

Control circuitry 16 may be used to run software on device 10 such as operating system code and applications. During operation of device 10, the software running on control circuitry 16 may display images on display 14 using an array of pixels in display 14.

Display 14 may have a rectangular shape (i.e., display 14 may have a rectangular footprint and a rectangular peripheral edge that runs around the rectangular footprint) or may have other suitable shapes. Display 14 may be planar or may have a curved profile.

A top view of a portion of display 14 is shown in FIG. 3. As shown in FIG. 3, display 14 may have an array of pixels 22. Pixels 22 may receive data signals over signal paths such as data lines D and may receive one or more control signals over control signal paths such as horizontal control lines G (sometimes referred to as gate lines, scan lines, emission control lines, etc.). There may be any suitable number of rows and columns of pixels 22 in display 14 (e.g., tens or more, hundreds or more, or thousands or more). Each pixel 22 may have a light-emitting diode 26 that emits light 24 under the control of a pixel control circuit formed from thin-film transistor circuitry such as thin-film transistors 28 and thin-film capacitors). Thin-film transistors 28 may be polysilicon thin-film transistors, semiconducting-oxide thin-film transistors such as indium zinc gallium oxide transistors, or thin-film transistors formed from other semiconductors.

A cross-sectional side view of a portion of an illustrative organic light-emitting diode display in the vicinity of one of light-emitting diodes 26 is shown in FIG. 4. As shown in FIG. 4, display 14 may include a substrate layer such as substrate layer 30. Substrate 30 may be formed from plastic or other suitable materials. Configurations for display 14 in which substrate 30 has been formed from a flexible material such as polyimide or other flexible polymer are sometimes described herein as an example.

Thin-film transistor circuitry 44 may be formed on substrate 30. Thin film transistor circuitry 44 may include layers 32. Layers 32 may include inorganic layers such as inorganic buffer layers, gate insulator, passivation, interlayer dielectric, and other inorganic dielectric layers. Layers 32 may also include organic dielectric layers such as a polymer planarization layer. Metal layers and semiconductor layers may also be included within layers 32. For example, semiconductors such as silicon, semiconducting-oxide semiconductors, or other semiconductor materials may be used in forming semiconductor channel regions for thin-film transistors 28. Metal in layers 32 may be used in forming transistor gate terminals, transistor source-drain terminals, capacitor electrodes, and metal interconnects.

As shown in FIG. 4, thin-film transistor circuitry 44 may include diode anode structures such as anode 36. Anode 36 may be formed from a layer of conductive material such as metal on the surface of layers 32 (e.g., on the surface of a planarization layer that covers underlying thin-film transistor structures). Light-emitting diode 26 may be formed within an opening in pixel definition layer 40. Pixel definition layer 40 may be formed from a patterned photoimageable polymer such as polyimide. In each light-emitting diode, organic emissive material 38 is interposed between a respective anode 36 and cathode 42. Anodes 36 may be patterned from a layer of metal. Cathode 42 may be formed from a common conductive layer that is deposited on top of pixel definition layer 40. Cathode 42 is transparent so that light 24 may exit light emitting diode 26. During operation, light-emitting diode 26 may emit light 24.

Metal interconnect structures may be used to interconnect transistors and other components in circuitry 44. Metal interconnect lines may also be used to route signals to capacitors, to data lines D and gate lines G, to contact pads (e.g., contact pads coupled to gate driver circuitry), and to other circuitry in display 14. As shown in FIG. 4, layers 32 may include one or more layers of patterned metal for forming interconnects such as metal traces 74.

If desired, display 14 may have a protective outer display layer such as cover glass layer 70. The outer display layer may be formed from a material such as sapphire, glass, plastic, clear ceramic, or other transparent material. Protective layer 46 may cover cathode 42. Layer 46 may include moisture barrier structures, encapsulant materials, adhesive, and/or other materials to help protect thin-film transistor circuitry. Functional layers 68 may be interposed between layer 46 and cover layer 70. Functional layers 68 may include a touch sensor layer, a circular polarizer layer, and other layers. A circular polarizer layer may help reduce light reflections from metal traces in thin-film transistor circuitry 44. A touch sensor layer may be formed from an array of capacitive touch sensor electrodes on a flexible polymer substrate. The touch sensor layer may be used to gather touch input from the fingers of a user, from a stylus, or from other external objects. Layers of optically clear adhesive may be used to attach cover glass layer 70 and functional layers 68 to underlying display layers such as layer 46, thin-film transistor circuitry 44, and substrate 30.

Display 14 may have an active area in which pixels 22 form images for viewing by a user of device 10. The active area may have a rectangular shape. Inactive portions of display 14 may surround the active area. For example, signal traces and other support circuitry such as thin-film display driver circuitry may be formed along one or more of the four edges of display 14 that run around the rectangular periphery of display 14 adjacent to the active area. If desired, one or more display driver integrated circuits may be mounted to

substrate **30** in the inactive border. For example, a flexible printed circuit on which one or more display driver integrated circuits have been mounted using solder may be attached to the border of display **14**. This type of configuration is sometimes referred to as a chip-on-flex configuration and allows display driver circuitry to supply signals to the data and gate lines on display **14**.

To minimize the amount of the inactive border area of display **14** that is visible to a user, one or more edges of display **14** may be bent. As an example, the edge of display **14** to which a display driver circuit is mounted using a chip-on-flex arrangement may be folded under the active area of display **14**. This helps minimize visible display borders and reduces the footprint of display **14**.

An illustrative display with a bent edge portion is shown in FIG. **5**. As shown in FIG. **5**, display **14** has portion **14A** (i.e., a planar active area portion that contains the active area of display **14** that is formed by an array of pixels **22**), bent portion **14B**, and inactive portion **14C**. If desired, connectors, display driver integrated circuits or other integrated circuits, flexible printed circuits, and/or other components may be mounted to inactive portion **14C** of display **14**.

Metal traces **74** may carry signals between inactive area **14C** of display **14** and active area **14A** of display **14** (i.e., metal traces **74** may traverse bent portion **14B** of display **14**). As shown in the cross-sectional side view of the illustrative display of FIG. **6**, when bent portion **14B** is bent around bend axis **72**, portion **14C** is folded under portion **14A** and is therefore hidden from view by a user such as viewer **80** who is viewing display **14** in direction **82**. As shown in FIG. **6**, components **76** (e.g., display driver circuitry, etc.) may be mounted on the upper and/or lower surface of display **14** in region **14C**. An optional support structure such as mandrel **78** may be used to support display **14** in bend region **14B** (e.g., to help establish a desired minimum bend radius in region **14B**) or, more preferably, mandrel **78** may be omitted to help minimize display thickness (e.g., by allowing portions **14A** and **14C** to be mounted more closely together and by allowing the bend radius for region **14B** to be reduced).

When bending display **14** in region **14B**, care should be taken to ensure that sensitive display structures do not become damaged. Stresses can be imparted to display structures in a flexible display when the display is bent. For example, metal traces such as metal traces **74** of FIG. **5** that are used to form signal lines that convey signals between display driver circuitry or other circuits in inactive region **14C** and pixels **22** in region **14A** may be subjected to bending stresses in bend region **14B**. To minimize bending stress and thereby minimize cracks in metal traces **74**, it may be desirable to align the neutral stress plane of display **14** in bend region **14B** with metal traces **74**.

As shown in FIG. **7**, when a portion of display **14** is bent in region **14B**, some layers such as substrate **30** may be subjected to compressive stress and some layers such as coating layer **84** may be subjected to tensile stress. Neutral stress plane **86** arises where stress has been eliminated by balancing the compressive stress and tensile stress. The shape of neutral stress plane **86** may be curved in a curved portion of display **14** such as portion **14B** of FIG. **7** (i.e., neutral stress plane **86** may have a curved profile).

The relative thicknesses of substrate **30** and coating **84** and the relative modulus of elasticity values for substrate **30** and coating **84** determine the location of the neutral stress plane within the layers of bent display region **14B**. For example, if the elasticity of substrate **30** and coating **84** is the same, neutral stress plane **86** can be aligned with metal

traces **74** by ensuring that coating **84** has the same thickness as substrate **30**. If, on the other hand, coating **84** has an elasticity that is larger than that of substrate **30**, coating **84** need not be as thick as substrate **30** to balance the compressive and tensile stresses.

FIG. **8** shows how coating **84** may be characterized by a thickness **TB** and elasticity **E2** and how substrate **30** may be characterized by a thickness **TA** and elasticity **E1**. The elasticity values **E1** and **E2** and the thickness values **TA** and **TB** may be selected to help ensure that region **14B** does not impart undesired stress to metal traces **74**. For example, thickness **TA** may be minimized (e.g., **TA** may be less than 16 microns, may be 5-15 microns, may be 8 microns, may be 6-12 microns, may be more than 5 microns, etc.) and substrate elasticity **E1** may be minimized (e.g., **E1** may be less than 9 GPa, may be less than 7 GPa, may be less than 5 GPa, may be 2-3 GPa, may be 1-5 GPa, or may be more than 0.5 GPa) to make flexible substrate **30** more flexible than would otherwise be possible.

The thickness **TB** and elasticity **E2** of coating **84** may be selected to balance the compressive stress produced when bending substrate **30**. With one suitable arrangement, the elasticity **E2** may be enhanced to help minimize the magnitude of thickness **T2** (and therefore reduce display thickness). The value of **E2** may be, for example, about 1 GPa, 0.7 to 1.3 GPa, more than 0.5 GPa, more than 0.7 GPa, more than 0.8 GPa, or less than 2 GPa (as examples). Substrate **30** may be, for example, polyimide and coating **84** may be, for example, a polymer adhesive that is thermally cured or that is cured by application of ultraviolet light.

FIG. **9** is a cross-sectional side view of an illustrative arrangement that may be used for bending display **14** (e.g., when it is desired to omit mandrel **78** of FIG. **6**). As shown in FIG. **9**, display **14** may have active portion **14A**, bent portion **14B**, and inactive portion **14C**. In active portion **14A**, moisture barrier film **90** may cover the array of organic light-emitting diode pixels **22** and other thin-film transistor circuitry **44** to prevent moisture damage. Layers **68** may be interposed between cover layer **70** and moisture barrier layer **90**. Layers **68** may include polarizer **68A** (which may be attached to film **90** with pressure sensitive adhesive), optically clear adhesive layer **68B**, touch sensor **68C**, and optically clear adhesive **68D** (as an example).

In region **14B**, coating **84** may be used to adjust the location of the neutral stress plane in display **14** to avoid damage to metal traces **74**.

Portion **14C** may be bent under portion **14A** and may be secured to the underside of portion **14A** using layers such as layers **92** and **98**. Layer **92** may include a polymer layer such as polymer substrate layer **94** and a pressure sensitive adhesive layer such as layer **96** that attaches layer **94** to substrate **30**. Layer **98** may include a polymer layer such as a polymer substrate **102** and a pressure sensitive adhesive layer such as layer **100** that attaches layer **102** to substrate **30**. Adhesive layer **96** may be interposed between layers **92** and **98** and may attach layer **94** to layer **102**, thereby attaching the folded portion of display **14** to itself. Layer **96** may be a foam adhesive, a layer of pressure sensitive adhesive, or other suitable adhesive. The thickness of layer **96** may be 30-250 microns, more than 25 microns, or less than 300 microns. The thickness of substrates **94** and **102** may be 100 microns, more than 50 microns, less than 150 microns, 70-130 microns, etc. The thickness of adhesive layers **96** and **100** may be 25 microns, more than 10 microns, less than 50 microns, etc.

Using an arrangement of the type shown in FIG. **9**, display thickness can be minimized by allowing the display to be

folded over against itself and attached together with adhesive (i.e., by allowing portion 14C to be folded and secured against portion 14A without use of a mandrel).

FIGS. 10, 11, and 12 are cross-sectional side views of additional configurations for the layers in displays with bent flexible substrates.

In the example of FIG. 10, layer 92 does not extend outwards as far as layer 98, so ledge portion 98L of layer 98 is exposed and the edges of layers 92 and 98 at the bent portion of display 14 are not aligned with each other. Arrangements of the type shown in FIG. 10 may help bend portion 14B of display 14 with a desired bend profile.

In the illustrative arrangement of FIG. 11, the edges of layers 98 and 92 (i.e., respective edge surfaces 98E and 92E) have been aligned with each other and have been aligned with edge surface (edge) 104E of adhesive layer 104. As with the arrangements of FIGS. 9 and 10, the use of this arrangement for layers 98 and 92 may be helpful in adjusting display 14 so that portion 14B exhibits a desired bend profile.

In some situations, it may be desirable for edge 104E of adhesive layer 104 to extend outwardly towards bent portion 14B of display 14 past edges 92E and 98E of layers 92 and 98. This type of arrangement is shown in FIG. 12. As shown in FIG. 12, adhesive layer 104 may protrude sufficiently far past edges 92E and 98E that edge surface 104E of layer 104 contacts and supports inner surface 301 of substrate 30. The use of a protruding adhesive layer such as layer 104 of FIG. 12 may help ensure that bent display portion 14B exhibits a desired bend profile.

Although sometimes described herein in the context of flexible displays, substrate 30 may be used to form any suitable devices. For example, circuitry may be formed on substrate 30 in regions 14A, 14B, and/or 14C that forms one or more touch sensors that are free of pixels (i.e., pixels 22 may be replaced by touch sensor electrodes, packaged sensors, or other sensor structures), that forms force sensors, or that forms other electrical components with or without including pixels on substrate 30. Thin-film circuitry and/or circuitry that forms part of a discrete device (e.g., integrated circuits etc.) may be formed on substrate 30 (e.g., in regions 14A, 14B, and/or 14C) and may include sensors, integrated circuits with sensor circuitry or other sensor structures, input-output circuitry, control circuitry, or other circuitry. If desired, the circuitry on substrate 30 may allow some or all of substrate 30 to serve as a signal cable (e.g., a flexible printed circuit cable that contains signal lines for routing signals between different portions of device 10). In arrangements such as these, metal traces may extend across bent region 14B to allow signal to pass between circuitry in regions 14A and 14C and, if desired, to route signals to and from circuitry in regions 14B. The use of a portion of substrate 30 in forming a display is merely illustrative.

The foregoing is merely illustrative and various modifications can be made by those skilled in the art without departing from the scope and spirit of the described embodiments. The foregoing embodiments may be implemented individually or in any combination.

What is claimed is:

1. A display, comprising:

a flexible substrate;

an array of pixels that form an active area on the flexible substrate;

metal traces that extend from the active area to an inactive area on the flexible substrate across a bend region on the flexible substrate, wherein the flexible substrate is folded over against itself at the bend region so that the

active area overlaps the inactive area, wherein the inactive area defines a plane parallel to the active area; first and second polymer layers interposed between the active area and the inactive area that is overlapped by the active area; and

first, second, and third adhesive layers, wherein the first adhesive layer is interposed between the first polymer layer and the active area of the flexible substrate and attaches the first polymer layer to the active area of the flexible substrate, wherein the second adhesive layer is interposed between the second polymer layer and the inactive area of the flexible substrate and attaches the second polymer layer to the inactive area of the flexible substrate, wherein the third adhesive layer is interposed between the first and second polymer layers and attaches the first and second polymer layers together, wherein the first, second, and third adhesive layers have aligned edges that are separated from the bent region of the flexible substrate by a gap, and wherein the first and second polymer layers and the first, second, and third adhesive layers are the only layers interposed between the active area of the flexible substrate and the plane defined by the inactive area of the flexible substrate.

2. The display defined in claim 1 wherein the flexible substrate is a polyimide substrate with a thickness of less than 16 microns.

3. The display defined in claim 1 wherein the flexible substrate is a polyimide substrate with an elasticity of less than 5 GPa.

4. The display defined in claim 1 wherein the flexible substrate is coated with a coating layer in the bend region that has an elasticity of more than 0.7 GPa.

5. The display defined in claim 4 wherein the flexible substrate is a polyimide substrate.

6. The display defined in claim 5 wherein the flexible substrate has a thickness of less than 16 microns.

7. The display defined in claim 1 wherein the first and second polymer layers have respective first and second edges at the bend region that are aligned with each other.

8. The display defined in claim 1 wherein the first and second polymer layers have respective first and second edges and, and wherein the respective first and second edges of the polymer layers are aligned with the aligned edges of the first, second, and third adhesive layers.

9. The display defined in claim 1 wherein the first and second polymer layers have respective first and second edges at the bend region that are not aligned with each other.

10. The display defined in claim 1 wherein the array of pixels comprises an array of organic light-emitting diode pixels.

11. A display, comprising:

a flexible substrate having opposing first and second surfaces;

an array of pixels that form an active area on the first surface of the flexible substrate, wherein the flexible substrate is folded at a bend region;

first and second polymer layers that are attached between a first portion of the second surface of the flexible substrate and a second portion of the second surface of the flexible substrate;

a first layer of adhesive between the first and second polymer layers, the first layer of adhesive having a first edge; and

a second layer of adhesive between the second polymer layer and the second portion of the second surface of the flexible substrate, the second layer of adhesive having a second edge aligned with the first edge.

12. The display defined in claim 11 further comprising metal traces that extend from the active area to an inactive area on the flexible substrate across the bend region, wherein the inactive area is free of pixels.

13. The display defined in claim 12 wherein the first layer of adhesive has a protruding portion that protrudes from between the first and second polymer layers and that contacts the flexible substrate.

14. The display defined in claim 11 wherein the array of pixels comprises an array of organic light-emitting diode pixels.

15. The display defined in claim 14 wherein the flexible substrate is coated with a coating layer in the bend region.

16. The display defined in claim 11, further comprising: a third layer of adhesive between the first polymer layer and the first portion of the second surface of the flexible substrate, wherein the third layer of adhesive has a third edge aligned with the first edge and with the second edge.

17. An organic light-emitting diode display, comprising: thin-film transistor circuitry that forms an array of pixels; a flexible substrate having a first surface on which the thin-film transistor circuitry is formed and having an opposing second surface, wherein the flexible substrate is bent back on itself in a bend region so that a first portion of the second surface faces a second portion of the second surface;

at least one polymer layer and at least one layer of adhesive that attach the first portion to the second portion; and

a polymer coating on the first surface of the flexible substrate, wherein the polymer coating overlaps a portion of the thin-film transistor circuitry so that the thin-film transistor circuitry is interposed between the polymer coating and the first surface, wherein the polymer coating is bent back on itself in the bend region and extends behind the first and second portions of the second surface of the flexible substrate to overlap the array of display pixels, the at least one polymer layer, and the at least one layer of adhesive.

18. The organic light-emitting diode display defined in claim 17 wherein the at least one polymer layer comprises first and second polymer layers, and wherein the at least one layer of adhesive includes adhesive between the first and second polymer layers that attaches the first polymer layer to the second polymer layer.

19. The organic light-emitting diode display defined in claim 17 further comprising:

a moisture barrier film that overlaps the thin-film transistor circuitry, wherein the polymer coating overlaps the moisture barrier film so that the moisture barrier film and the thin-film transistor circuitry are interposed between the polymer coating and the first surface.

20. An apparatus, comprising:
a flexible substrate;

an array of pixels on the flexible substrate that form an active area of the flexible substrate, wherein the active area has a rectangular shape that is surrounded by an inactive area;

metal traces that extend from the active area to the inactive area on the flexible substrate across a bend region on the flexible substrate, wherein the flexible substrate is folded over against itself at the bend region so that the active area overlaps the inactive area;

first and second polymer layers interposed between the active area and the inactive area that is overlapped by the active area; and

first, second, and third adhesive layers, wherein the first adhesive layer is interposed between the first polymer layer and the active area of the flexible substrate and attaches the first polymer layer to the active area of the flexible substrate, wherein the second adhesive layer is interposed between the second polymer layer and the inactive area of the flexible substrate and attaches the second polymer layer to the inactive area of the flexible substrate, wherein the third adhesive layer is interposed between the first and second polymer layers and attaches the first and second polymer layers together, and wherein the inactive area of the flexible substrate overlaps at least half of the active area of the flexible substrate.

21. The apparatus defined in claim 20 wherein the flexible substrate is a polyimide substrate with a thickness of less than 16 microns.

22. The apparatus defined in claim 20 wherein the flexible substrate is a polyimide substrate with an elasticity of less than 5 GPa.

23. The apparatus defined in claim 20 wherein the flexible substrate is coated with a coating layer in the bend region that has an elasticity of more than 0.7 GPa.

24. The apparatus defined in claim 20 wherein the flexible substrate is a polymer substrate.

25. The apparatus defined in claim 20 wherein the flexible substrate is a polymer substrate, the apparatus further comprising:

an array of sensor structures in the active area.

26. The apparatus defined in claim 20 wherein the first and second polymer layers have respective first and second edges and wherein the third adhesive layer has a protruding portion that extends from between the first and second polymer layers past the first and second edges.

27. The apparatus defined in claim 20, wherein the first and second polymer layers overlap at least half of the active area of the flexible substrate.

28. The apparatus defined in claim 27, wherein the first, second, and third adhesive layers overlap at least half of the active area of the flexible substrate.

* * * * *

专利名称(译)	柔性显示面板，带有弯曲基板		
公开(公告)号	US9614168	公开(公告)日	2017-04-04
申请号	US14/987129	申请日	2016-01-04
[标]申请(专利权)人(译)	苹果公司		
申请(专利权)人(译)	苹果公司.		
当前申请(专利权)人(译)	苹果公司.		
[标]发明人	ZHANG ZHEN TAO YI DRZAIC PAUL S WURZEL JOSHUA G		
发明人	ZHANG, ZHEN TAO, YI DRZAIC, PAUL S. WURZEL, JOSHUA G.		
IPC分类号	H01L27/32 H01L23/498 H01L23/538 H01L51/52 H01L51/00		
CPC分类号	H01L51/0097 H01L23/4985 H01L23/5387 H01L27/326 H01L27/3276 H01L51/004 H01L51/5253 H01L2251/5338 H01L2251/558 G09F9/33 H01L27/32 H01L27/3244 H01L27/3246 Y02E10/549		
代理人(译)	TREYZ, G VICTOR		
优先权	62/102284 2015-01-12 US		
其他公开文献	US20160204366A1		
外部链接	Espacenet USPTO		

摘要(译)

显示器可以具有在柔性基板上形成有源区域的有机发光二极管阵列。金属迹线可以在有源区域和柔性基板的无效区域之间延伸。诸如显示驱动器集成电路的显示器驱动器电路可以耦合到非活动区域。金属迹线可以延伸穿过柔性基板中的弯曲区域。柔性基板可以在弯曲区域中弯曲。柔性基板可以由薄的柔性材料制成以减少金属迹线弯曲应力。弯曲区域中的涂层可以具有增强的弹性以允许其厚度减小。柔性基板可以在其自身上弯曲并固定在电子设备中而不使用心轴。

